

# i SERIES

COMPACT LASER CUTTING MACHINE

1.5kW-12kW



## Advantages

- A compact design sheet fiber laser metal cutting machine with complete protection.
- Small occupied space balances complete protection and higher safety.
- The whole lightning-quick piercing process completes during BodorGenius moves down on Z-axis. Cutting performance and efficiency are improved, reworking is avoided for medium/thick sheet piercing.

# SELF-DEVELOPED CONTROL SYSTEM



## Advantages

- Bodor Laser independent research and development system, perfect combination with BodorGenius laser head, brings to customers upgraded cutting technology and efficiency.
- BodorThinker
  - Integration of CAD and CAM can directly identify drawings and nest
  - Good adaptability, support G code(NC)、DXF、PLT、ENG and other file formats
  - The newly added batch processin function, in conjunction with the processing data-base, makes it more convenient in batch cutting.
  - The updated CAM logic and more open CAM function make it more convenient to change drawings, use more comprehensively, and easier to cut.

# INTELLIGENT FUNCTIONS



## A new generation of safety following module

- Laser head keeping distance with work piece in cutting process can reduce collision risks. It will stop cutting when colliding plate. The safety following module reduces accident rate and improves cutting performance.

# STRETCHED ALUMINUM GANTRY(i5)

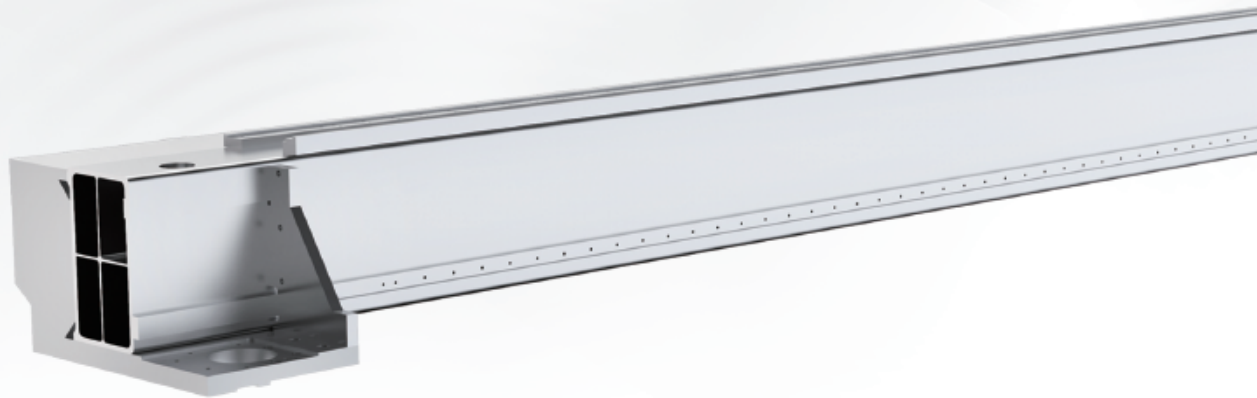

## Advantages

---

- Integral pressure casting by steel mold makes it light, flexible and efficient
- The light weight and strong rigidity of aluminum alloy are suitable for high speed movement during processing, and the high flexibility is beneficial to high-speed cutting of various graphics.
- Light crossbeam offers high operation speed, improving efficiency and ensuring quality.

# BODOR CLOUD

## Advantages

---

- Daily equipment status management ( processing data, report forms )
- Alarm and maintenance reminder
- Cloud transmission for processing programs
- Remote online service access with one key
- Real-time information of the latest cutting process

# INTELLIGENT FUNCTIONS

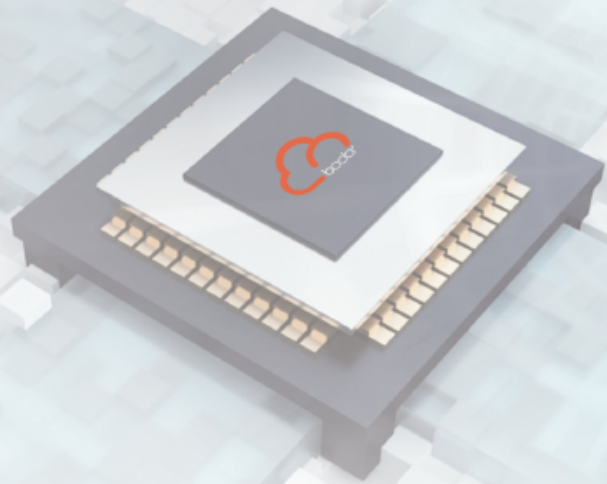

## Intelligent alarm system

- The system will start full abnormal alarm and push it to the interface through control center when equipment is abnormal.
  - Finding equipment abnormal in advance and reducing hidden dangers can multiply improve the equipment troubleshooting efficiency.
- 

## Various intelligent sensor modules

- Various intelligent sensor modules to improve safety and device protection

# INTELLIGENT FUNCTIONS

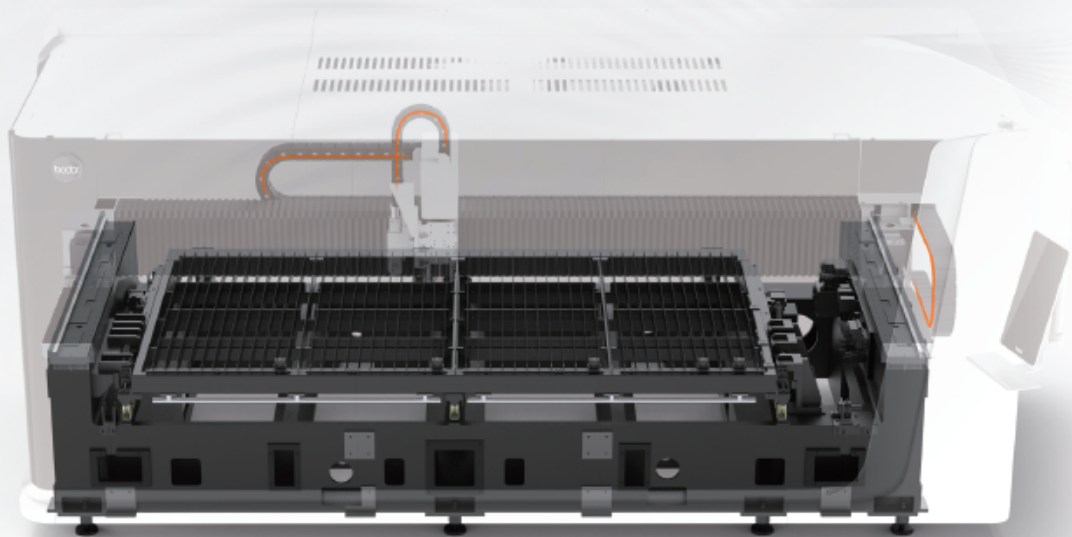

## Automatic lubrication system

- Automatic lubrication system provides timing and ration lubricating oil for equipment to ensure its normal and high speed operation, and owns functions of abnormal alarm and liquid level alarm. The system greatly enhances cutting accuracy and effectively extends service life of transmission mechanism.
- 

## Intelligent travel protection

- Automatically monitor operation range of crossbeam and cutting parts, keeping operation within machining range. Double guarantees of fixed limitation greatly improve equipment and personal safety, minimizing the using risks.

# ELECTRIC VERTICAL DOOR & PULL-OUT TABLE

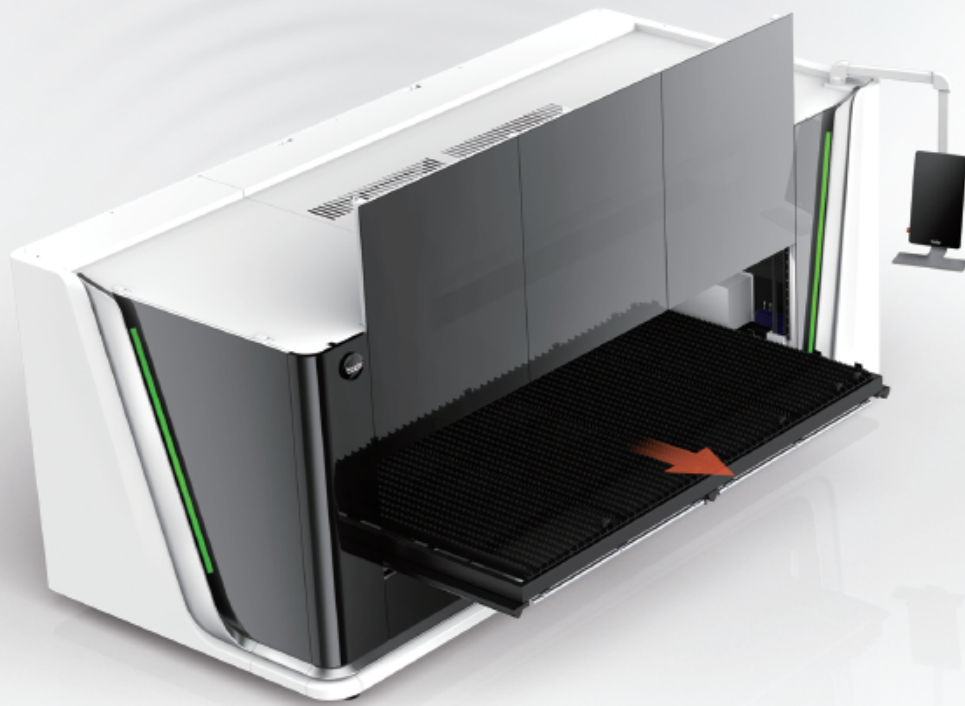

## Advantages

---

- Side door design; Easy, fast opening and closing with just one finger's press
- The new manual pull-out table design and optional electric table make operation experience fresh and satisfying. (Available only for i7)

## Cutting Samples



**Layout**

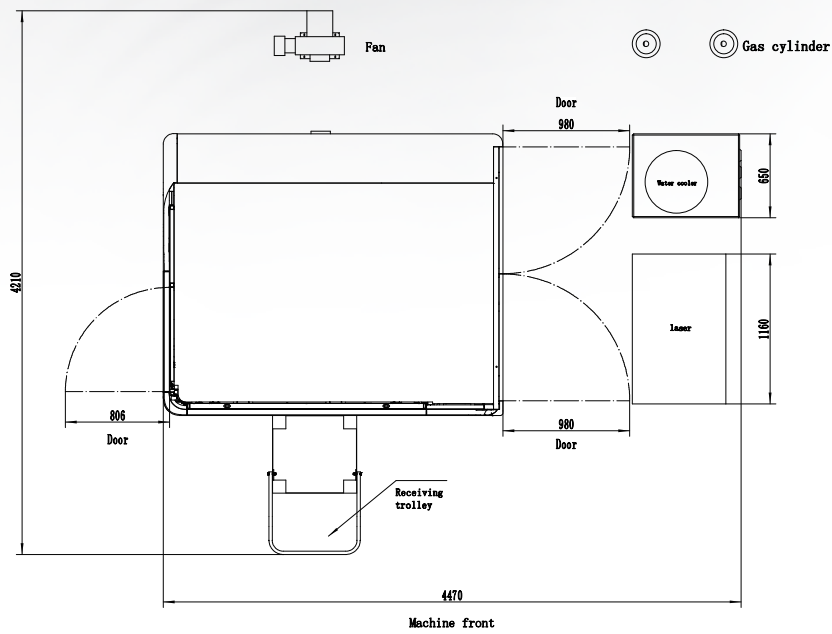
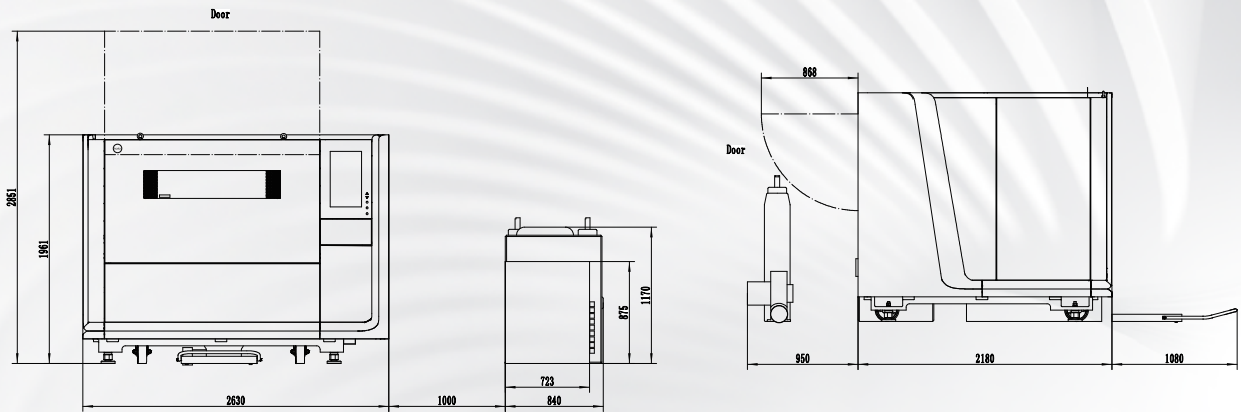

The above layout drawings and figures are for reference only, the actual drawing shipped with machine prevails.



**i7**  
3048mm\*1524mm

**i5**  
1000mm\*1500mm

## Technical Data

ITEM	i7	i5
Working area	3048*1524mm	1000*1500mm
Max. linkage speed	100m/min	100m/min
Max. acceleration	1.5G	1.5G
Table load bearing	900kg	250kg
Machine overall dimensions	4955×2320×2200	2980×2220×1970
Overall weight	4980kg	2000kg
Z axis travel	120mm	100mm
Positioning accuracy	±0.05mm/m	±0.05mm/m
Repositioning accuracy	±0.03mm	±0.03mm
Total power capacity/current with 12kW source	96.1kVA/146.1A	×
Total power capacity/current with 6kW source	57.5kVA/87.3A	49.3KVA/75A
Total power capacity/current with 3kW source	51.1KVA/77.7A	43KVA/65.3A
Total power capacity/current with 1.5kW source	39.8KVA/60.4A	single-phase: 31.6KVA/143.8A three-phase: 30.8KVA/48.1A

## Configuration And Components

laser head	Bodor Genius	
Laser source	Bodor Thinker	
Machine bed	Mortise-and-tenon type plate welded segmented bed	
Bed functions	Easy-access sliding bed	Stationary bed (optional pneumatic sheet-clamping)
X-axis、Y-axis、Z-axis Servo motor and driver	Bodor	
Linear Rails	Bodor	
Rack	Bodor	
Protective Enclosure	●	
Control system	Bodor Thinker	
Display size	21.5 inches	
Water Chiller	●	
Dust removal	Centrifugal fan	

## Additional options

Laser protective glasses	<input type="radio"/>	Voltage regulator (Including 10m power line)	<input type="radio"/>
Integrated compressed air system	<input type="radio"/>	laser fume filter (Made in China)	<input type="radio"/>
125mm focus distance laser head (3-4kw)	<input type="radio"/>	Nitrogen proportional valve	<input type="radio"/>
Electric countertop	i7 <input type="radio"/>	BodorNest	<input type="radio"/>
Bodor MES	<input type="radio"/>	Mixed gas cutting function	<input type="radio"/>
security light curtains	<input type="radio"/>	Double pneumatic clamping table	i5 <input type="radio"/>

## Cutting Parameters

		1000W	1500W	2000W	3000W	6000W	12kW	15kW	22kW	30kW
	Thickness	speed m/min	speed m/min	speed m/min	speed m/min	speed m/min	speed m/min	speed m/min	speed m/min	speed m/min
"Carbon steel (Q235A) O2"	1	8.0-10	8.0-10	8.0-10	8.0-10	8-10	9-11	9-11	9-11	9-11
	2	4.5-5.5	4.5-5.5	4.0-6.0	5.5-7.5	5-7.5	5-7.5	5-7.5	5-7.5	5-7.5
	3	2.4-3.0	2.5-3.4	3.0-4.0	3.0-4.0	3.5-5	3.5-5.5	3.5-5.5	3.5-5.5	3.5-5.5
	4	1.8-2.2	2.1-2.4	2.8-3.3	2.8-3.5	3.0-4.5	3.5-5	3.5-5	3.5-5	3.5-5
	5	1.6-1.8	2.0-2.5	2.2-2.8	2.6-3.2	3.0-4.2	3.3-4.8	3.3-4.8	3.3-4.8	3.3-4.8
	6	1.2-1.3	1.6-1.8	1.8-2.3	2.5-2.6	2.5-3.5	3.0-4.2	3.0-4.2	3.0-4.2	3.0-4.5
	8	0.6-0.8	1.0-1.2	1.2-1.7	1.6-1.8	2.2-3.2	2.5-3.8	2.5-3.8	2.5-3.9	2.5-3.9
	10		0.7-0.9	1.0-1.2	1.4-1.6	1.8-2.5	2.2-3.6	2.2-3.6	2.0-3.8	2.2-3.8
	12		0.7-0.8	0.8-1.0	1.0-1.4	1.2-2.1	1.2-3.5	1.2-3.6	1.6-3.8	1.6-3.8
	14		0.5-0.7	0.6-0.85	0.8-0.9	1.2-1.8	1.7-3.3	1.5-3.5	1.5-3.8	1.6-3.8
	16			0.6-0.75	0.7-0.8	0.8-1.5	1.2-3.1	1.2-3.5	1.4-3.7	1.5-3.7
	18				0.6-0.7	0.6-1.2	1.0-2.7	1.2-3.0	1.4-3.6	1.4-3.6
	20				0.5-0.6	0.5-0.8	0.6-2.4	1.2-2.7	1.5-3.5	1.5-3.5
	25					0.3-0.55	0.5-1.6	0.8-1.8	1.0-3.0	1.0-3.1
	30						0.3-1.0	0.6-1.4	0.8-2.2	1.2-2.6
	35						0.3-0.7	0.4-0.7	0.6-1.0	0.9-2.2
	40						0.2-0.4	0.3-0.5	0.5-1.1	0.8-1.7
45						0.2-0.3	0.2-0.5	0.3-0.6	0.5-0.8	
50								0.2-0.6	0.4-0.6	
60								0.2-0.5	0.2-0.4	
"Stainless steel (201) N2"	1	18-20	20-30	24-50	30-55	42-52	70-85	72-100	72-100	72-100
	2	5.0-7.0	8.0-16	9.0-17	12-30	20-33	40-66	45-70	50-75	50-75
	3	2.2-4.0	3.0-5.5	4.0-7.0	6.0-10.0	15-22	35-45	38-50	38-55	38-55
	4	1.2-2.3	1.5-3.2	3.2-4.0	4.0-6.0	10-15	20-32	25-35	25-33	30-35
	5		0.7-1.5	2.0-2.7	3.0-5.0	7.0-12	18-25	20-30	22-30	25-32
	6		0.7-1.3	1.2-1.8	2.0-3.2	4.8-9.0	12-15	15.0-25.0	17-25	18-26
	8			0.7-1.2	1.0-1.8	3.0-4.0	8-12	8.0-12.0	12-18	15-20
	10				0.5-0.85	1.6-2.5	6.0-8.0	6.0-10.0	8.0-12.0	12-15
	12				0.4-0.5	0.8-1.5	4.0-5.5	4.0-6.0	6.0-9	8-12
	14					0.6-1.2	3.0-5.0	3.5-5.5	5.0-7.0	6-10.5
	16					0.5-1.0	2.2-2.8	2.5-3.0	3.0-5.0	5-9
	18					0.4-0.8	1.2-2.0	1.2-2.2	1.8-4.2	3-6.5
	20					0.3-0.6	1.0-1.6	1.3-1.8	1.5-3.3	2-4.7
	25						0.5-0.8	0.6-1.2	1.5-2.0	1.8-2.5
	30						0.3-0.6	0.5-1.0	1.0-1.5	1.5-1.8
	35						0.3-0.5	0.4-0.8	0.4-0.8	1.0-1.5
	40						0.3-0.5	0.3-0.6	0.3-0.6	0.6-1.3
45							0.2-0.5	0.2-0.6	0.8-1.0	
50							0.1-0.5	0.2-0.5	0.25-0.5	
60							0.1-0.2	0.1-0.3	0.2-0.3	
70									0.17-0.3	
80									0.15-0.3	
"Aluminum N2"	1	8-10	10-15	15-25	25-30	42-55	60-85	70-100	70-100	70-100
	2	2.8-3.6	5.0-7.0	7-10	13-20	20-40	38-50	40-55	40-70	40-70
	3	0.7-1.1	2.0-2.6	4.0-8.0	6.5-7.5	15-25	30-40	35-45	35-60	35-60
	4		1.0-1.4	2.5-3.0	3.5-5.0	9.5-12	20-30	30-40	30-43	30-45
	5		0.5-0.7	1.2-2.5	2.5-3.5	5.0-8.0	15-25	20-30	22-35	22-34.0
	6			0.6-0.9	1.5-2.5	3.8-5.0	10-15	15-24	18-28	18-32
	8				0.7-1.0	2.0-2.5	7.0-12	8.0-12.0	12-20	12-23
	10					1.0-1.5	4.5-8.0	5.0-9.0	7.0-12.0	7.0-16
	12					0.8-1.3	4.0-5.0	4.0-6.0	4.5-6.5	4.5-12
	14					0.9-1.2	1.8-2.7	2.5-3.2	3.0-4.0	3.0-8.0
	16					0.5-0.8	1.5-2.5	2.0-3.0	2.5-3.5	2.5-6
	18					0.5-0.7	1.0-1.8	1.5-1.9	1.8-2.2	1.8-2.2
	20					0.5-0.7	0.9-1.5	1.3-1.8	1.5-2.0	1.5-2.0
	25						0.6-0.9	0.6-1.2	0.8-1.5	0.8-1.5
30						0.3-0.8	0.5-1.0	0.6-1.2	0.6-1.2	
35						0.3-0.6	0.3-0.8	0.4-0.9	0.4-0.9	
40						0.3-0.4	0.3-0.5	0.3-0.5	0.4-0.6	
"Brass N2"	1	6.0-10	8.0-13	10-16	20-30	35-45	55-65	60-70	65-75	65-75
	2	2.8-3.2	3.0-4.5	5.0-6.0	6.0-10	20-30	38-42	40-45	40-60	40-60
	3		1.5-2.5	2.5-7.0	3.0-8.0	12-18	18-30	20-35	25-40	25-40
	4		0.8-1.2	1.8-3.0	2.5-4.0	8.0-12.0	15-20	18-30	20-35	20-35
	5				1.5-2.0	6.0-8.0	10-15	15-20	20-28	20-30
	6				1.0-1.8	3.0-6.5	6.0-8.0	8-15	12-20	12-22
	8					1.6-2.2	5.0-7.0	8.0-10.0	9.0-12	9.0-15
	10					0.8-1.2	4.5-6.0	5.0-6.5	6.0-10	6.0-13
	12					0.3-0.5	2.4-4.0	2.8-4.2	3.0-4.5	5.0-10
	14						0.8-1.5	1.0-1.8	1.8-4.0	3.0-7.0
	16						0.6-1.2	0.8-1.5	1.5-3.0	1.5-3.0
	18						0.4-0.6	0.6-0.8	1.0-2.5	1.2-2.5
	20							0.4-0.6	0.4-2.0	1.2-2.0
	25								0.3-0.5	0.5-0.8
30									0.4-0.6	

Note: This parameter is for reference only. Various conditions on site (sheet quality, gas quality, etc.) have a lot of influence, so it cannot be used as the basis for acceptance or quality traceability. The final interpretation right belongs to Bodor Laser!

## Cutting Capacity

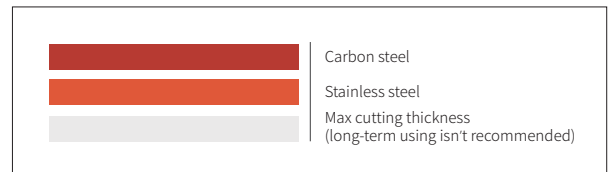
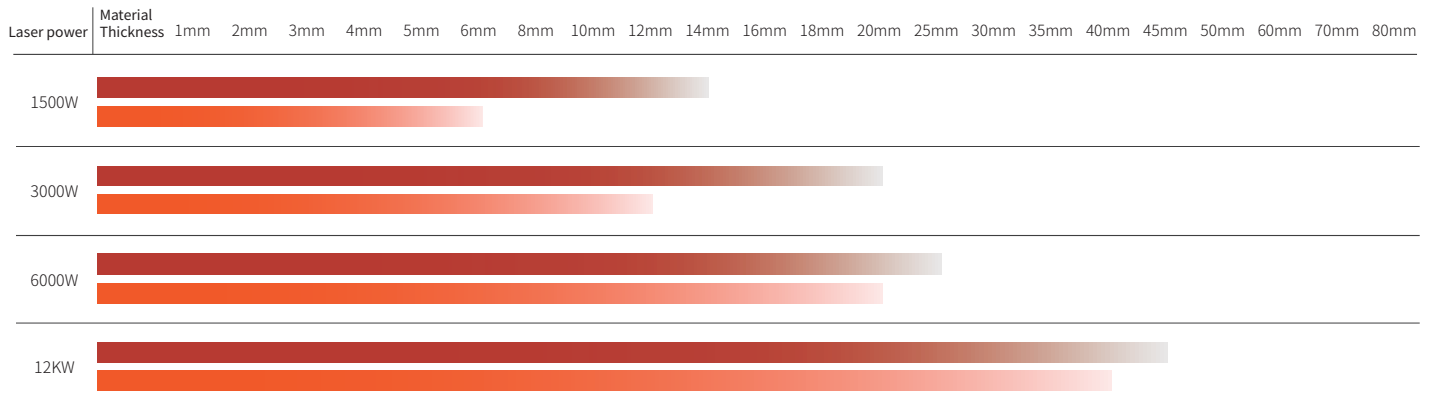

Above data is only for reference

# THE BLACK GO CHESS

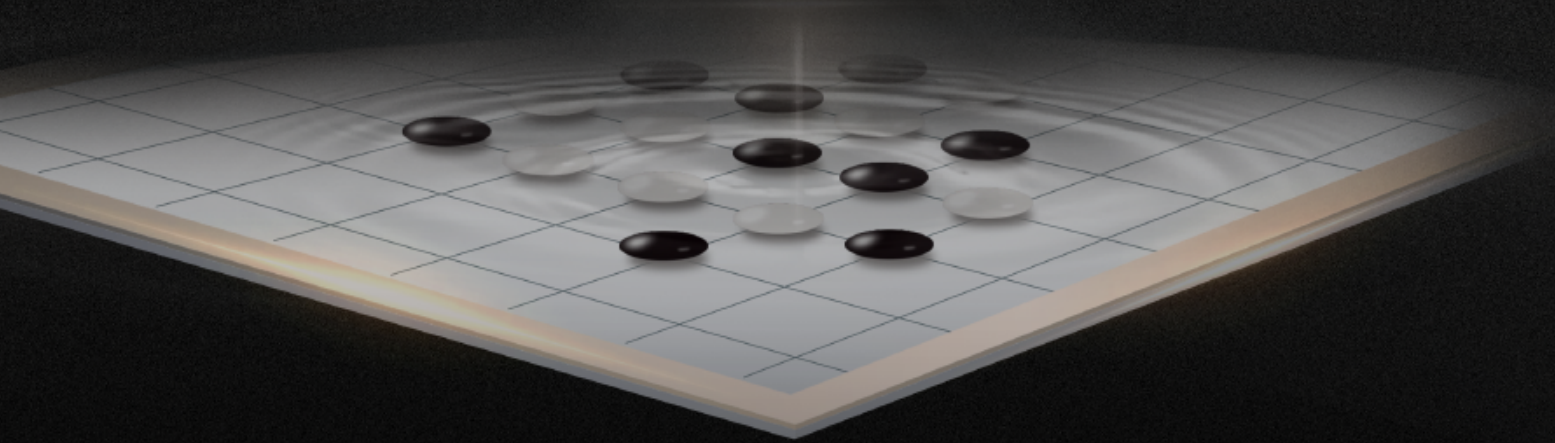

Black Go chess — inspired by Go

Circular — endless loop, endless exploration

Black — derived from obsidian crystal, steady and deep



# INTRODUCTION

Now the company has more than 2,000 employees from more than 20 countries around the world. Headquartered in Jinan, China, Bodor sets up 9 oversea subsidiaries, respectively in the US, India, Hungary, Turkey, Brazil, Mexico, Japan, South Korea, and Germany. The global footprint of Bodor has now covered over 180 countries and regions on six continents, building a complete sales channel and service network around the world to provide global customers with the best laser cutting application solutions.

**51000m<sup>2</sup>**

Production Base

**7000+**

Delivery Capability

**2000+**

Global Employees



# COMPANY HISTORY

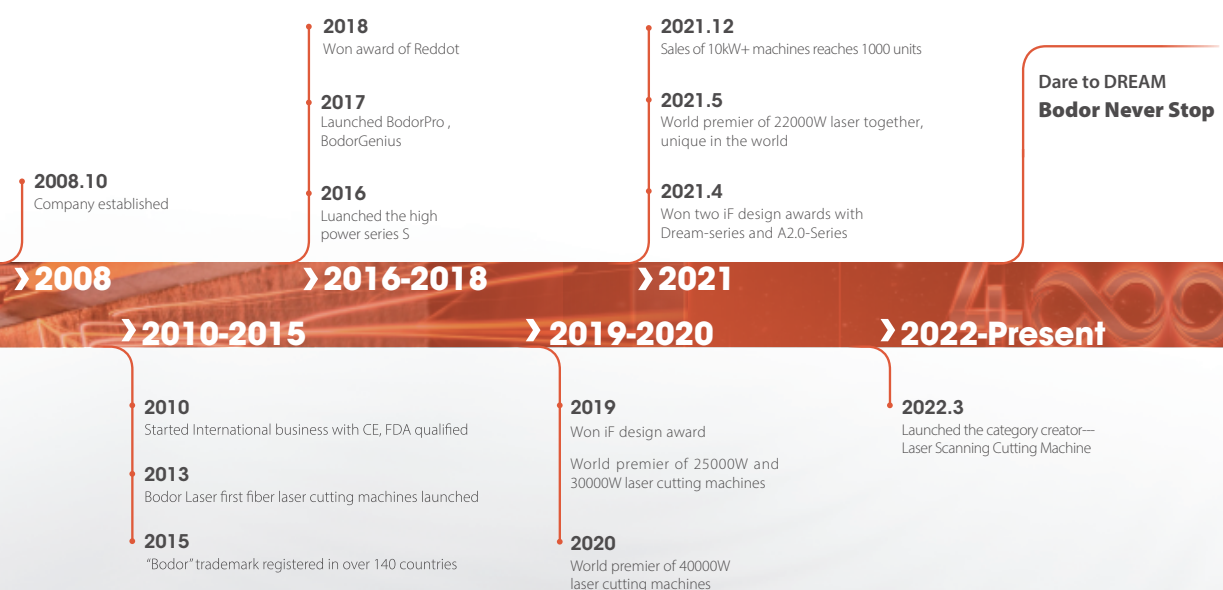

# GLOBAL NETWORK

**180**  
countries covered

**10+**  
global branches

**4**  
Technical centers



## ULTRA-HIGH POWER CAPABILITY

● **World premier**

World premier of 25000w, 30000w, 40000w and world unique 22000w laser cutting machine.

● **Sales record(Until 31th, Dec. 2021)**

Choice of 1000 companies worldwide on 10kW+ laser cutting machines, in 46 different countries and regions

● **No. 1**

Leading sales volume of 10kW+ laser cutting machines

# R&D CAPABILITY



- Strong R&D team lead by the drafter of National Standards for CNC laser cutting machines
- Over 200 R&D Technicians, the R&D level is in line with international standards
- 10 subdivision platforms, including plate cutting, pipe cutting, application engineering, etc.
- 2 core R&D Centers in China and 4 overseas Technology Centers
- More than 200 patent certificates, 5 international awards, 22 industry awards

 **200+**  
R&D Team

 **200+**  
Patents

 **10**  
R&D Platform

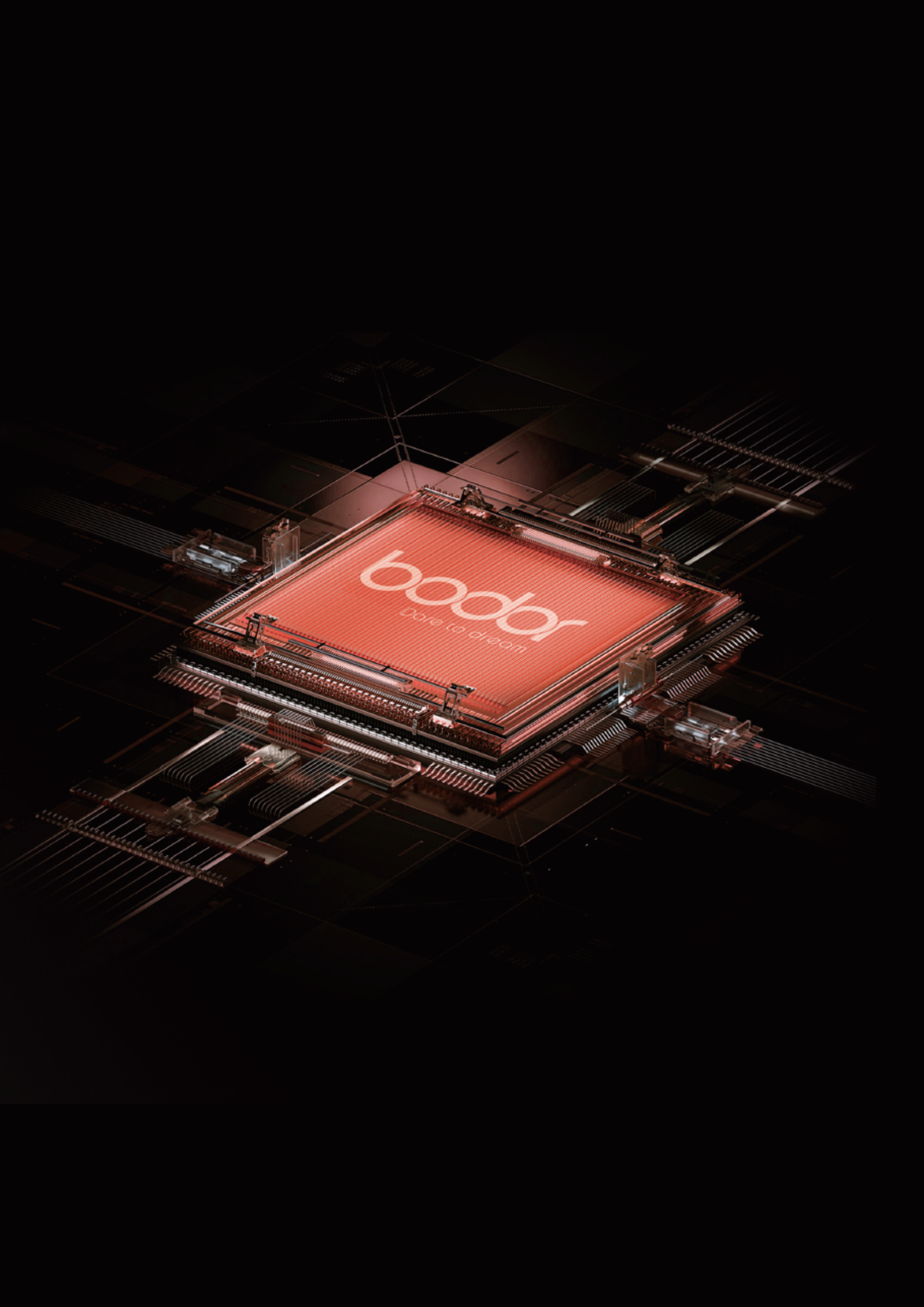

boddor  
Care to dream